

Generalized Glucocorticoid Resistance

a report by

George P Chrousos, MD,¹ Tomoshige Kino, MD, PhD² and Evangelia Charmandari, MD¹

1. Division of Endocrinology and Metabolism, Clinical Research Center, Biomedical Research Foundation of the Academy of Athens;

2. Section of Pediatric Endocrinology, Eunice Kennedy Shriver National Institute of Child Health and Human Development

DOI: 10.17925/USE.2008.04.2.100

Glucocorticoids are steroid hormones synthesized and secreted by the adrenal cortices under the regulation of the hypothalamic–pituitary–adrenal (HPA) axis. Glucocorticoids regulate a broad spectrum of physiological functions essential for life and play an important role in the maintenance of basal and stress-related homeostasis.^{1–4} At the cellular level, the actions of glucocorticoids are mediated by the human glucocorticoid receptor (hGR), which belongs to the steroid/thyroid/retinoic acid nuclear receptor superfamily of transcription factor proteins and is expressed in virtually all cells.^{5,6} The gene encoding hGR α (hGR gene) is one locus on the long arm of chromosome 5 (q31.3), and consists of nine exons spanning over 150kb. Expressed hGR α is a panel of eight amino terminal translational isoforms of varying lengths, each of which consists of three subdomains: the N-terminal (NTD), the DNA-binding (DBD), and the ligand-binding (LBD) domains. In our expression and functional studies referred to here we have employed as representative the longest GR α isoform, comprising 777 amino acids. The

hGR gene also produces an equal number of hGR β isoforms by the use of an alternative 3' exon 9 β , which cannot bind glucocorticoids and exerts a dominant negative effect on the transcriptional activity of hGR α .^{1,5,6}

In the absence of ligand, hGR α resides mostly in the cytoplasm of cells as part of a hetero-oligomeric complex, which contains chaperon heat shock proteins (HSPs) 90, 70, 23, and FKBP51, as well as other proteins.⁷ Upon ligand-induced activation, the receptor dissociates from this multiprotein complex and translocates into the nucleus through the nuclear pore with the energy-dependent mechanism that includes importin α and β . Inside the nucleus, hGR α binds as a homodimer to glucocorticoid response elements (GREs) in the promoter regions of target genes and regulates their expression positively or negatively, depending on GRE sequence and promoter context.^{7–10} The ligand-activated hGR α can also modulate gene expression independently of DNA binding by interacting, possibly as a monomer, with other transcription factors such as nuclear factor- κ B (NF- κ B), activator protein-1 (AP-1), p53, and signal transducers and activators of transcription (STATs)^{11–14} (see *Figure 1a*). To initiate the transcription, hGR α uses its transcriptional activation domains, activation function (AF)-1 and AF-2, located in NTD and LBD, respectively, as surfaces to interact with co-activators or co-repressors.^{15–19} The p160 co-activators such as the glucocorticoid receptor-interacting protein 1 (GRIP1) play an important role in the hGR α -mediated transactivation of glucocorticoid-responsive genes given that they interact directly with both the AF-1 of hGR α through their carboxyl-terminal domain and the AF-2 through multiple amphipathic LXXLL signature motifs located in their nuclear receptor-binding (NRB) domain.²⁰ They also have histone acetyltransferase (HAT) activity, which promotes chromatin decondensation and facilitates initiation of transcription^{15–18} (see *Figure 1b*).

Alterations in the molecular mechanisms of hGR α action may lead to alterations in tissue sensitivity to glucocorticoids, which may take the form of resistance or hypersensitivity and may be associated with significant morbidity.^{21–24} In this article we summarize the molecular mechanisms underlying primary generalized glucocorticoid resistance and secondary, inflammation-induced, generalized glucocorticoid resistance.

Primary Generalized Glucocorticoid Resistance

Primary generalized glucocorticoid resistance is a rare condition characterized by generalized, partial target-tissue insensitivity to glucocorticoids.^{25–30} This leads to activation of the HPA axis and compensatory elevations in circulating cortisol and adrenocorticotrophic hormone (ACTH) concentrations, which maintain circadian rhythmicity



George P Chrousos, MD, FAAP, MACP, MACE, is a Professor and Chairman in the Department of Pediatrics at the University of Athens School of Medicine in Athens, and former Chief of the Pediatric and Reproductive Endocrinology Branch of the National Institute of Child Health and Human Development (NICHD), National Institutes of Health (NIH). He has made major contributions to neuroendocrinology: he has written over 1,000 scientific papers and his work has been cited in more than 40,000 other scientific articles, an irrefutable testimony to the importance and influence of his research.



Tomoshige Kino, MD, PhD, is Acting Chief of the Section of Pediatric Endocrinology, Program in Reproductive and Adult Endocrinology of the Eunice Kennedy Shriver National Institute of Child Health and Human Development (NICHD), National Institutes of Health (NIH). He has made major contributions to nuclear receptor biology. He has worked on glucocorticoid hormones and their intracellular receptor for over 10 years, and has investigated the tissue factors that regulate glucocorticoid actions in target organs. He has written over 100 scientific papers in prestigious journals and book chapters.



Evangelia Charmandari, MD, is a Senior Investigator in the Division of Endocrinology and Metabolism at the Clinical Research Center at the Biomedical Research Foundation of the Academy of Athens, and a Consultant Pediatric and Adolescent Endocrinologist in the Department of Endocrinology, Metabolism, and Diabetes at the Evgenidion Hospital of the National and Kapodistrian University of Athens. Her clinical and molecular research studies have primarily focused on the hypothalamic–pituitary–adrenal axis, adrenal disorders, glucocorticoid signaling, and the molecular mechanisms of glucocorticoid receptor action.

E: evangelia.charmandari@gmail.com

and appropriate responsiveness to stressors. The excess ACTH secretion results in adrenal hyperplasia and increased production of adrenal steroids with mineralocorticoid and/or androgenic activity^{25–30} (see *Figure 2*).

The clinical manifestations of primary generalized glucocorticoid resistance are summarized in *Table 1* and relate to the pathophysiological alterations depicted in *Figure 2*. The clinical spectrum of the condition is broad and ranges from most severe to mild forms, while a number of patients may be asymptomatic, displaying only biochemical alterations^{25–42} (see *Table 1*). The variable clinical phenotype of primary generalized glucocorticoid resistance may be due to: variations in the glucocorticoid, mineralocorticoid, or androgen receptor signaling pathways; variations in the degree of tissue sensitivity to glucocorticoids, mineralocorticoids, and/or androgens; variations in the activity of key hormone-inactivating or -activating enzymes, such as the 11 β -hydroxysteroid dehydrogenase⁴³ and 5 α -reductase;⁴⁴ and other genetic or epigenetic factors, such as insulin resistance and visceral obesity.²⁷

Molecular Mechanisms of Primary Generalized Glucocorticoid Resistance

The molecular basis of primary generalized glucocorticoid resistance has been ascribed to mutations in the hGR gene that impair the molecular mechanisms of hGR action and reduce tissue sensitivity to glucocorticoids. We have identified most hGR gene mutations associated with primary generalized glucocorticoid resistance and studied the molecular mechanisms through which the corresponding mutant receptors affect glucocorticoid signal transduction. More specifically, we determined: the transcriptional activity of the mutant receptors; the ability of the mutant receptors to exert a dominant negative effect upon the wild-type receptor; the affinity of the mutant receptors for the ligand; the subcellular localization of the mutant receptors and their nuclear translocation following exposure to the ligand; the ability of the mutant receptors to bind to GREs; the interaction of the mutant receptors with the GRIP1 co-activator; and the motility of the mutant receptors within the nucleus of living cells.^{25–42,45,46} The molecular defects elucidated in the reported cases are summarized in *Table 2*, while the corresponding mutations in the hGR gene are shown in *Table 2* and *Figure 3*.

All mutant receptors demonstrated variable reduction in their ability to transactivate the glucocorticoid-responsive mouse mammary tumor virus (MMTV) promoter in response to dexamethasone compared with the wild-type receptor, with the most severe impairment observed in the cases of R477H, I559N, V571A, and D641V mutations.^{31–42} The mutant receptors hGR α I559N, hGR α F737L, hGR α I747M, and hGR α L773P exerted a dominant negative effect on the wild-type receptor that might have contributed to manifestation of the disease at the heterozygote state.^{31,35,38,40,42}

All mutant receptors in which the mutation is located in the LBD of the hGR α showed a variable reduction in their affinity for the ligand, with the most severe reduction observed in the cases of I559N, I747M, and V571A mutations.^{31–42} The decreased affinity of the mutant receptors for the ligand most likely reflects the location of the mutations in the LBD of hGR α . The mutant receptor hGR α R477H, in which the mutation is located at the DBD of the receptor, demonstrated normal affinity for the ligand⁴¹ (see *Figure 2*). In the absence of dexamethasone, the wild-type hGR α was primarily localized in the cytoplasm of cells. The pathological

Figure 1a: Nucleocytoplasmic Shuttling of the Glucocorticoid Receptor

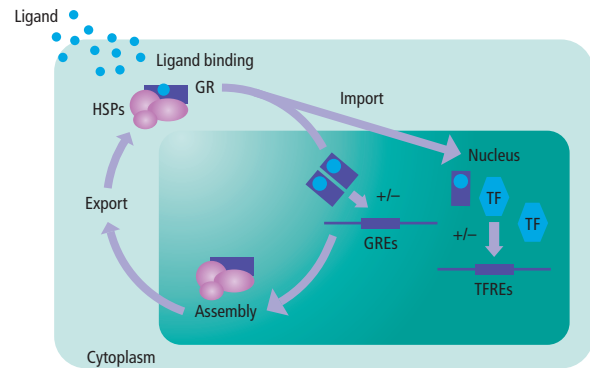

Upon ligand binding, the activated human glucocorticoid receptor (hGR)- α dissociates from heat shock proteins (HSPs) and translocates into the nucleus, where it binds as a homodimer to glucocorticoid response elements (GREs) in the promoter region of target genes or interacts as a monomer with other transcription factors.

Figure 1b: Schematic Representation of the Interaction of Activation Function-1 and -2 of Human Glucocorticoid Receptor- α with Co-activators

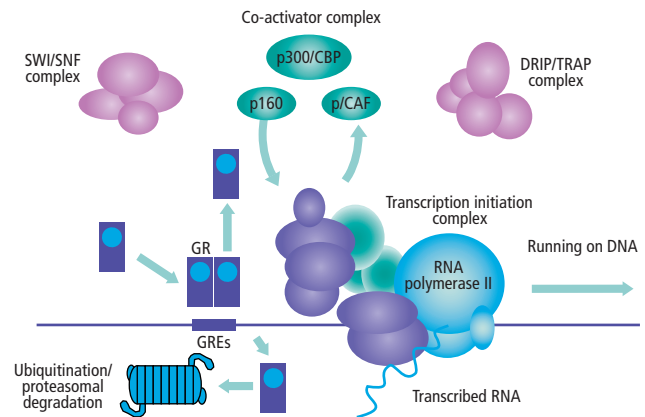

AF = activation function; DRIP/TRAP = vitamin D receptor-interacting protein/thyroid hormone receptor-associated protein; GR = glucocorticoid receptor; GREs = glucocorticoid response elements; HSP = heat shock protein; SWI/SNF = switching/sucrose non-fermenting; TF = transcription factor; TFREs = transcription factor response elements.

mutant receptors were also localized in the cytoplasm of cells in the absence of ligand, except for hGR α V729I and hGR α F737L, which were localized in both the cytoplasm and the nucleus of cells. The addition of dexamethasone (10⁻⁶M) resulted in translocation of the wild-type receptor into the nucleus within 12 minutes, but a much slower translocation of the mutant receptors into the nucleus, which ranged from 20 minutes (R477H) to 180 minutes (I559N and F737L).^{31–42} These findings suggest that all hGR mutations affect the nucleocytoplasmic shuttling of hGR α , probably through impairment of the function of the nuclear localization signals NL1 and/or NL2.^{47–50} Defective mechanisms that may relate to delayed nuclear export, such as the calreticulin export pathway and certain motifs in the DBD that function as nuclear export signals, may account for the nuclear localization of the unliganded hGR α V729I and hGR α F737L,^{51,52} an effect that may be similar to the nuclear retention mechanism of hGR α .³⁵

Figure 2: Alterations in the Hypothalamic–Pituitary–Adrenal Axis in Primary Generalized Glucocorticoid Resistance

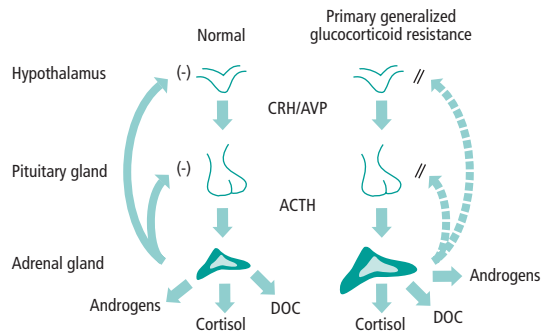

The impaired glucocorticoid feedback inhibition at the hypothalamic and anterior pituitary levels results in increased secretion of corticotropin-releasing hormone (CRH) and adrenocorticotropic hormone (ACTH), adrenal hyperplasia, and increased secretion of adrenal steroids with mineralocorticoid and/or androgenic activity. AVP = arginine vasopressin; DOC = deoxycorticosterone.

Table 1: Clinical Manifestations and Diagnostic Evaluation of Generalized Glucocorticoid Resistance*

Clinical Manifestations

Apparently normal glucocorticoid function

- Asymptomatic
- Chronic fatigue (glucocorticoid deficiency?)

Mineralocorticoid excess

- Hypertension
- Hypokalemic alkalosis

Androgen excess

- Children: Ambiguous genitalia at birth, ** premature adrenarche, precocious puberty
- Females: Acne, hirsutism, male-pattern hair loss, menstrual irregularities, oligo-anovulation, infertility
- Males: Acne, hirsutism, oligospermia, adrenal rests in the testes, infertility

Increased HPA axis activity (CRH/ACTH hypersecretion)

- Anxiety
- Adrenal rests

Diagnostic Evaluation

Absence of clinical features of Cushing syndrome

Normal or elevated plasma ACTH concentrations

Elevated plasma cortisol concentrations

Increased 24-hour urinary free cortisol excretion

Normal circadian and stress-induced pattern of cortisol and ACTH secretion

Resistance of the HPA axis to dexamethasone suppression

Thymidine incorporation assays: Increased resistance to dexamethasone-induced suppression of phytohemagglutinin-stimulated thymidine incorporation compared with control subjects

Dexamethasone-binding assays: Decreased affinity of the glucocorticoid receptor for the ligand compared with control subjects

Molecular studies: Mutations/deletions of the glucocorticoid receptor

*Modified from reference 27.

**This is the only case of ambiguous genitalia documented in a child with 46,XX karyotype who also harbored a heterozygous mutation of the 21-hydroxylase gene.

The wild-type and all mutant receptors in which the mutations are located in the LBD of hGR α preserved their ability to bind to DNA.^{31–42} The only mutant receptor that failed to bind to DNA was hGR α R477H, in which the mutation is located at the C-terminal zinc finger of the DBD of

the receptor.⁴¹ A major function of the C-terminal zinc finger of the DBD of hGR α is to contribute to receptor homodimerization, a prerequisite for potent receptor binding to GREs and efficient transactivation of glucocorticoid-responsive genes.^{53,54} Point mutations in the DBD of the hGR may abolish DNA binding, resulting in silencing of transcriptional activation, although they may not affect the ability of the mutant receptors to transrepress AP-1-, NF- κ B-, and/or other target-gene-dependent transcription, possibly through protein–protein interactions and/or tethering of other co-factors to the transcriptional machinery.^{54–57}

We next investigated the interaction between the mutant receptors and the GRIP1 co-activator *in vitro*. GRIP1 contains two sites that bind to steroid receptors: one site, the NRB site, is located at the central part of the protein and interacts with the AF-2 of hGR α in a ligand-dependent fashion, while the other site is located at the carboxyl-terminus of the protein and binds to the AF-1 of hGR α in a ligand-independent fashion.^{58–60} The wild-type and most mutant receptors bound to full-length GRIP1 and the carboxyl-terminal fragment of GRIP1, but not to the NRB fragment of GRIP1, suggesting that they interact with the GRIP1 co-activator *in vitro* only through their AF-1. Exceptions were the receptors hGR α R477H, which interacted with both the AF-1 and AF-2 of hGR α , and hGR α I559N, which did not interact with either fragment of GRIP1.^{31–42} These findings suggest that the hGR mutant receptors may form a defective complex with GRIP1, which is partially or completely ineffective. Furthermore, the mutant receptors may also display an abnormal interaction with other AF-2-associated proteins such as the p300/CBP co-integrators and components of the vitamin D-receptor interacting protein (DRIP)/thyroid-hormone-receptor-associated proteins (TRAP) complex.^{15–18} Using fluorescence recovery after photobleaching (FRAP) analysis, we demonstrated that all hGR pathological mutant receptors had defective transcriptional activity and dynamic motility defects inside the nucleus of living cells.⁴⁶ In the presence of dexamethasone, these mutants displayed a curtailed 50% recovery time ($t^{1/2}$) after photobleaching and, hence, significantly increased intranuclear motility and decreased chromatin retention. The $t^{1/2}$ values of the mutants correlated positively with their transcriptional activities and depended on the hGR domain affected. Therefore, the motility defect of the mutant receptors is a good overall index of functionality.⁴⁶

In summary, mutations in the hGR gene impair the molecular mechanisms of glucocorticoid action and lead to generalized tissue insensitivity to glucocorticoids. A consequent increase in the activity of the HPA axis compensates for the reduced sensitivity of peripheral tissues to glucocorticoids at the expense of ACTH hypersecretion-related pathology. The study of the molecular defects of natural hGR mutants enhances our understanding of hGR action and highlights the importance of integrated cellular and molecular signaling mechanisms in maintaining homeostasis and preserving normal physiology.

Secondary Generalized Glucocorticoid Resistance Associated with Systemic Inflammation and Chronic Inflammatory Diseases

Acute and chronic inflammatory processes and diseases such as sepsis, asthma, rheumatoid arthritis, and inflammatory bowel disease are characterized by increased expression of multiple inflammatory genes. The latter are regulated by pro-inflammatory transcription factors such as

Table 2: Mutations of the Human Glucocorticoid Receptor Gene Causing Generalized Glucocorticoid Resistance

Author (Reference)	Mutation Position		Molecular Mechanisms	Genotype	Phenotype
	cDNA	Amino acid			
Chrousos et al. ²⁷	1922 (A→T)	641 (D→V)	Transactivation ↓	Homozygous	Hypertension
Hurley et al. ³²			Affinity for ligand ↓ (x 3) Nuclear translocation: 22 minutes Abnormal interaction with GRIP1		Hypokalemic alkalosis
Karl et al. ³³	4 bp deletion in exon-intron 6 Inactivation of the affected allele		hGR α number: 50% of control	Heterozygous	Hirsutism Male-pattern hair loss Menstrual irregularities
Malchoff et al. ³⁴	2185 (G→A)	729 (V→I)	Transactivation ↓ Affinity for ligand ↓ (x 2) Nuclear translocation: 120 minutes Abnormal interaction with GRIP1	Homozygous	Precocious puberty Hyperandrogenism
Karl et al. ³¹	1676 (T→A)	559 (I→N)	Transactivation ↓	Heterozygous	Hypertension
Kino et al. ³⁵			Decrease in hGR binding sites Transdominance (+) Nuclear translocation: 180 minutes Abnormal interaction with GRIP1		Oligospermia Infertility
Ruiz et al. ³⁶	1430 (G→A)	477 (R→H)	Transactivation ↓	Heterozygous	Hirsutism
Charmandari et al. ⁴¹			No DNA binding Nuclear translocation: 20 minutes		Hypertension
Ruiz et al. ³⁶	2035 (G→A)	679 (G→S)	Transactivation ↓	Heterozygous	Hirsutism
Charmandari et al. ⁴¹			Affinity for ligand ↓ (x 2) Nuclear translocation: 30 minutes Abnormal interaction with GRIP1		Fatigue Hypertension
Mendonca et al. ³⁷	1712 (T→C)	571 (V→A)	Transactivation ↓ Affinity for ligand ↓ (x 6) Nuclear translocation: 25 minutes Abnormal interaction with GRIP1	Homozygous	Ambiguous genitalia Hypertension Hypokalemia Hyperandrogenism
Vottero et al. ³⁸	2241 (T→G)	747 (I→M)	Transactivation ↓ Transdominance (+) Affinity for ligand ↓ (x 2) Nuclear translocation ↓ Abnormal interaction with GRIP1	Heterozygous	Cystic acne Hirsutism Oligo-amenorrhea
Charmandari et al. ⁴⁰	2318 (T→C)	773 (L→P)	Transactivation ↓ Transdominance (+) Affinity for ligand ↓ (x 2.6) Nuclear translocation: 30 minutes Abnormal interaction with GRIP1	Heterozygous	Fatigue Anxiety Acne Hirsutism Hypertension
Charmandari et al. ⁴²	2209 (T→C)	737 (F→L)	Transactivation ↓ Transdominance (time-dependent) (+) Affinity for ligand ↓ (x 1.5) Nuclear translocation: 180 minutes	Heterozygous	Hypertension Hypokalaemia

cDNA = complementary DNA; GRIP1 = glucocorticoid receptor-interacting protein 1.

NF- κ B and AP-1, which play a critical role in amplifying and perpetuating the inflammatory process. Furthermore, inflammation-mediated activation of the nervous system and the HPA axis is an integral component in the regulation of the innate and adaptive immune response.⁶¹ Cytokines and inflammatory mediators activate the HPA axis both directly and indirectly. Activation of the HPA axis has profound inhibitory effects on the immune/inflammatory response.⁶² At the cellular level, the main anti-inflammatory and immunosuppressive effects of glucocorticoids include alterations in leukocyte traffic and function, decreases in production of cytokines and mediators of inflammation, and inhibition of their action on target tissues by the latter. It is worth noting that hyperactivity or hypoactivity of the HPA axis leads to dysregulation

of this neuroendocrine loop and may lead to systemic changes in inflammation and immunity.^{61,62}

Glucocorticoids represent the most effective anti-inflammatory treatment for many of the above inflammatory conditions.^{63,64} However, failure to respond to glucocorticoid therapy (glucocorticoid resistance) or need for chronic glucocorticoid treatment to maintain disease remission (glucocorticoid dependence) is common among patients treated with glucocorticoids and may be associated with significant morbidity and/or mortality. This variable response to glucocorticoid therapy is likely to be due to the process of inflammation, the disease itself, or the genetic background of the patient.^{63,64}

Figure 3: Known Mutations of the Human Glucocorticoid Receptor Gene (Upper Panel) and Protein (Lower Panel)

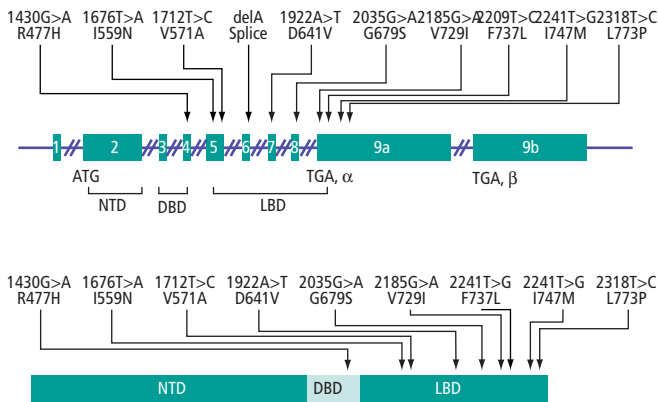

DBD = DNA-binding domain; NTD = amino terminal domain; LBD = ligand-binding domain.

Anti-inflammatory Glucocorticoid Signaling Mechanisms

Glucocorticoids are important in suppressing several inflammatory pathways. For example, glucocorticoids inhibit prostaglandin production through three independent mechanisms: the induction and activation of annexin I, the induction of mitogen-activated protein kinase (MAPK) phosphatase 1, and the repression of transcription of cyclo-oxygenase 2. Annexin I (also called lipocortin-1) is an anti-inflammatory protein that physically interacts with and inhibits cytosolic phospholipase A2 (cPLA2), which in turn blocks the release of arachidonic acid and its subsequent conversion to eicosanoids (i.e. prostaglandins, thromboxanes, prostacyclins, and leukotrienes).⁶²⁻⁶⁴ Glucocorticoids also induce MAPK phosphatase 1, an anti-inflammatory protein that dephosphorylates and inactivates Jun N-terminal kinase (JNK), thereby inhibiting c-Jun-mediated transcription of inflammatory and immune genes.⁶⁴ MAPK phosphatase 1 also dephosphorylates and inactivates all members of the MAPK family of proteins, including JNK, extracellular-signal-related kinase 1 and 2, and p38 kinase. Consequently, MAPK phosphatase 1 may also inhibit cPLA2 activity by blocking its phosphorylation by MAPKs and MAPK-interacting kinase. Furthermore, glucocorticoids and the hGR directly interfere with c-Jun-mediated transcription. The transcriptional interference between the hGR and c-Jun homodimers and/or c-Jun-Fos heterodimers occurs through protein-protein interactions and has proved to be a major anti-inflammatory mechanism of glucocorticoids.⁶⁴

In addition to the above, the glucocorticoid-hGR complex physically interacts with NF-κB to block its transcriptional activity.⁶⁵ NF-κB is a heterogeneous collection of dimers, the most common form consisting of a p65 and a p50 subunit. In its inactive state, NF-κB is sequestered in the cytoplasm by an inhibitory protein, the IκB. Tumor necrosis factor (TNF)-α, interleukin (IL)-1, microbial pathogens, viral infections, and other inflammatory signals trigger signaling cascades that activate IκB kinases. Phosphorylation of IκB leads to its ubiquitination and degradation by the proteasome, thereby unmasking a nuclear localization signal on NF-κB. In the nucleus, NF-κB binds DNA sequences, the NF-κB response elements, and stimulates the transcription of cytokines, chemokines, cell-adhesion molecules, complement factors, and receptors for these molecules. NF-κB also induces the transcription of cyclo-oxygenase 2, an enzyme essential for prostaglandin production (see *Figures 4a* and *4b*). A more detailed

description of the interactions between the hGR and the NF-κB signaling systems are discussed in the following section.^{64,65}

Glucocorticoids may also have rapid effects on inflammation that are not mediated by alterations in gene expression but, rather occur through membrane-associated receptors and second messengers (non-genomic actions)⁶⁶ (see *Figures 4a* and *4b*). Another mechanism of glucocorticoid-induced inhibition of inflammation involves decreased stability of messenger RNA (mRNA) for genes coding for inflammatory proteins, such as vascular endothelial growth factor and cyclo-oxygenase 2.⁶⁷ Therefore, glucocorticoids act on diverse target tissues through multiple mechanisms to control inflammation.

Molecular Mechanisms of Glucocorticoid Resistance Associated with Systemic Inflammation and Chronic Inflammatory Diseases

Abnormalities of the Human Glucocorticoid Receptor

Research studies on T-lymphocytes and other target inflammatory cells have demonstrated several hGR abnormalities as potential mechanisms influencing response to glucocorticoid treatment in inflammatory conditions. Several studies have demonstrated that cytokines modulate glucocorticoid sensitivity. IL-1β, IL-2, IL-4, IL-6, IL-13, TNF-α, and interferon (IFN)-γ alter hGR numbers and binding affinity,⁶⁸⁻⁷² while IL-2 and IL-4 enhance the expression of hGRβ, a hGR splicing variant that acts as a dominant negative inhibitor of hGRα-mediated transactivation of glucocorticoid-responsive genes.^{73,74} Patients with steroid-resistant asthma may display decreased hGRβ binding affinity,⁶⁹ abnormalities in hGR-AP-1 binding,⁷⁵ and increased expression of hGRβ.⁷⁶ Increased hGRβ mRNA expression in peripheral lymphocytes has also been documented in patients with steroid-resistant ulcerative colitis (UC)⁷⁷ and steroid-resistant rheumatoid arthritis.⁷⁸

Inflammation and NF-κB

A substantial part of the anti-inflammatory actions of hGRα are mediated by its interference with the potent transcription factor NF-κB, which results in inhibition of the synthesis of cytokines and other gene products of the inflammatory cascade, such as chemokines, cell adhesion molecules, complement factors, and receptors for these molecules. Glucocorticoids (GCs) penetrate the cell membrane readily and exert their effects through activation of the hGR, which translocates into the nucleus and influences NF-κB activity in five major ways: by physically interacting with the p65 subunit with formation of an inactive (GC-hGRα/NF-κB) complex;^{79,80} by inducing the synthesis of the inhibitory protein IκBα via interaction with GREs in the promoter region of the IκB gene;^{79,80} by blocking the degradation of IκBα via enhanced synthesis of IL-10;^{79,80} by impairing TNF-α-induced degradation of IκBα;^{79,80} and by competing for limited amounts of hGRα co-activators, such as CREB-binding protein and steroid receptor co-activator-1.^{79,80} IκBα, in addition to maintaining NF-κB in an inactive state in the cytoplasm of cells, also translocates into the nucleus, where it binds activated NF-κB complexes to induce their export to the cytoplasm^{65,79,80} (see *Figure 4b*).

On the other hand, NF-κB can repress the transcriptional activity of hGRα. In a regulated response, GC-hGRα activation is sufficient to maintain NF-κB levels in homeostasis and achieve a reduction in transcription of inflammatory

mediators over time. Studies that examined the activities of GC-hGR α and NF- κ B in patients with systemic inflammation and acute respiratory distress syndrome (ARDS) showed that those who improved on treatment with moderate doses of glucocorticoids had an excess activation of GC-hGR α compared with NF- κ B, as evidenced by the increased GC-hGR α binding to NF- κ B and increased nuclear GC-hGR α binding (GC-hGR α -driven response). On the other hand, non-improvers demonstrated an excess of NF- κ B activation compared with GC-hGR α , leading to protracted transcription of inflammatory mediators over time. In non-improvers, GC-hGR α binding to NF- κ B was modestly increased, while nuclear NF- κ B binding to its respective response elements increased substantially over time and nuclear GC-hGR α and cytoplasmic I κ B α levels declined (NF- κ B-driven response).^{79,80}

Further studies that assessed the activity of NF- κ B in biopsy specimens from steroid-resistant and steroid-sensitive patients with severe Crohn's disease (CD) and UC showed that NF- κ B activation was mainly noted in lamina propria macrophages in steroid-sensitive patients and in epithelial cells in steroid-resistant patients.⁸¹ Similar were the findings related to the activation of AP-1 and the upstream kinases p38 and JNK.⁸² The functional interference of these pro-inflammatory mediators with the glucocorticoid response was supported by reporter gene assays, which demonstrated that NF- κ B, JNK, and p38 inhibited the transcriptional activity of hGR α . These findings suggest that the generalized glucocorticoid resistance documented in patients with systemic inflammation, CD, and UC is associated with constitutive activation of NF- κ B and stress-activated protein kinases, which may inhibit the anti-inflammatory action of a limited number of hGR α molecules by reducing the transcriptional activity of hGR α .

The Multidrug Resistance Gene

The multidrug resistance gene (MDR1) codes for a drug efflux pump P-glycoprotein-170, which is expressed on the apical surface of lymphocytes and intestinal epithelial cells and actively transports glucocorticoids and other drugs out of target cells, thereby reducing their efficacy. Increased expression of MDR1 has been demonstrated in peripheral T-lymphocyte and intestinal epithelial cells of patients with CD and UC who did not respond to glucocorticoid therapy.⁸³ This suggests that a subset of patients with refractory CD and UC might escape effective immunosuppression by steroids and other immunosuppressive agents including cyclosporin because these drugs are MDR substrates and are effectively 'pumped out' of target cells. Increased T-lymphocyte MDR1 expression has also been demonstrated in patients with rheumatoid arthritis who require glucocorticoids,⁸⁴ renal graft recipients who undergo graft rejection on cyclosporin therapy,⁸⁵ and patients with systemic lupus erythematosus.⁸⁶ Specific MDR pump inhibitors (e.g. PSC 833) can significantly increase intracellular human intestinal epithelial and T-lymphocyte levels of cortisol and cyclosporin,⁸⁷ and may have therapeutic applications in overcoming glucocorticoid resistance in many inflammatory conditions.

Histone Acetylation

The repression of genes occurs through the reversal of histone acetylation that activates inflammatory genes.⁸⁸ The ligand-bound hGR α may bind to CBP and other co-activators directly to inhibit their HAT activity,⁸⁹ thereby reversing the unwinding of DNA around core histones and suppressing inflammatory genes. Furthermore, the activated hGR α may also recruit histone deacetylase 2 (HDAC2) to the activated transcriptional complex, which results in deacetylation of hyperacetylated histones and a decrease

Figure 4a: General Mechanisms of Action of Glucocorticoids and Glucocorticoid Receptor in the Inhibition of Inflammation

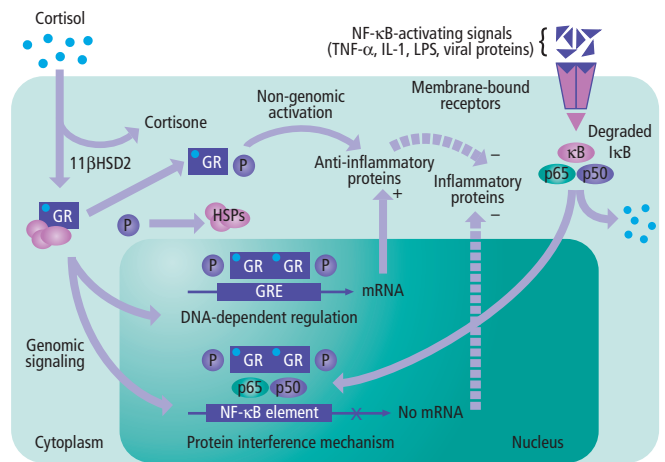
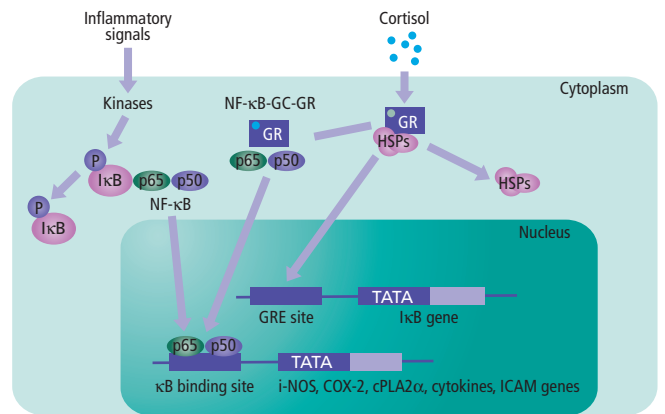

Figure 4b: Interaction Between NF- κ B and Activated Glucocorticoid Receptor



When cells are stimulated by inflammatory signals, specific kinases phosphorylate the inhibitory protein I κ B and cause its rapid degradation. The activated form of NF- κ B then moves to the nucleus initiating the transcription of mRNA of inflammatory cytokines, chemokines, cell adhesion molecules, and inflammation-associated enzymes (cyclo-oxygenase, phospholipase A2, and inducible nitric oxide). Cortisol or exogenous GCs freely cross into the cytoplasm and bind to their specific receptors and influence NF- κ B activity. COX-2 = cyclo-oxygenase-2; cPLA2 α = cytosolic phospholipase A2 α ; GC = glucocorticoid; GR = glucocorticoid receptor; GRE = glucocorticoid response element; HSP = heat shock protein; 11 β HSD2 = 11 β -hydroxy-steroid dehydrogenase type 2; ICAM = intercellular adhesion molecule; IL-1 = interleukin-1; iNOS = inducible nitric oxide synthase; LPS = lipopolysaccharide; mRNA = messenger RNA; NF- κ B = nuclear factor- κ B; P = phosphate; TNF- α = tumor necrosis factor- α . Solid arrows denote activation, while dashed arrows denote inhibition and/or repression.

in inflammatory gene transcription.⁸⁹ Several chronic inflammatory conditions such as asthma, rheumatoid arthritis, inflammatory bowel disease, and chronic obstructive pulmonary disease (COPD) are characterized by a high degree of oxidative stress that decreases HDAC2 activity and leads to reduced glucocorticoid sensitivity.⁹⁰ Indeed, there is a correlation between HDAC activity and the suppressive effects of glucocorticoids on cytokine release.⁹⁰ The reduced HDAC2 expression in alveolar macrophages in patients with COPD was restored following overexpression of HDAC2 using a viral vector, and this effect was associated with restoration of glucocorticoid responsiveness in these cells. In contrast, transfection with an HDAC1 vector failed to restore corticosteroid responsiveness in COPD cells.⁹¹

Acetylation of Human Glucocorticoid Receptor

Non-histone proteins are also acetylated by histone acetyltransferases (HATs) and deacetylated by HDACs, and this may be an important mechanism of regulating their function.⁹² Acetylation of several nuclear receptors including the estrogen and androgen receptors may affect binding to their ligands.⁹³ Acetylation of the hGR occurs after ligand-binding and prior to nuclear translocation.⁹¹ The acetylated hGR is deacetylated by HDAC2 and this deacetylation is necessary for the hGR to be able to inhibit NF- κ B activation of inflammatory genes.⁹¹ The site of acetylation of the hGR is the lysine-rich 'hinge' region 492–495 (sequence KKTK), which is analogous to the acetylation sites identified in other nuclear hormone receptors. Site-directed mutagenesis of the lysine residues K494 and K495 prevents hGR acetylation and reduces the activation of the SLPI gene by glucocorticoids, whereas repression of NF- κ B is unaffected.⁹¹

A reduction in HDAC2 activity prevents deacetylation of acetylated hGR so that glucocorticoids are no longer able to repress NF- κ B-activated inflammatory genes, which required deacetylation of the liganded receptor.⁹¹ Moreover, this results in excessive acetylated hGR, which may then bind to GREs to induce genes responsible for the side effects of glucocorticoids. Therefore, a reduction in HDAC2 activity may lead not only to glucocorticoid resistance and poor disease control, but also to increased incidence of glucocorticoid side effects.

Post-translational Modifications

Cytokines may also impair hGR action through post-translational modifications. Phosphorylation and dephosphorylation of the hGR plays

an important role in ligand binding, recycling, and turnover of the receptor. MAPKs, extracellular regulated kinases (ERKs), JNK, and p38 MAPK phosphorylate the hGR and inhibit hGR β -mediated transcriptional activation.^{94,95} This may represent an early repression effect of mitogenic and pro-inflammatory signals on the expression of hGR-dependent genes.

Conclusion

In summary, glucocorticoid resistance associated with acute or chronic inflammation is characterized by insensitivity of the immune system to glucocorticoids. The underlying molecular mechanisms involve alterations in genomic and non-genomic glucocorticoid signaling mechanisms leading to impaired glucocorticoid signal transduction and inefficient suppression of the inflammatory process. The response to glucocorticoid treatment varies considerably among individuals depending on the type and severity of inflammation and the genetic background of the patient. Variations in the activity of the HPA axis and the stress response in general, as well as the presence of mutations or polymorphisms in the hGR gene, may also account for the variable response to treatment. ■

Acknowledgments

The literary work of this article was funded by grants from the Intramural Research Program of the Eunice Kennedy Shriver National Institute of Child Health and Human Development (NICHD), the National Institutes of Health (NIH), Bethesda, Maryland, 20892, US, the EU–European Social Fund, and the Greek Ministry of Development and General Secretariat of Research and Technology in Athens.

- Kino T, Chrousos GP, In Handbook of Stress and the Brain, 2005;295–311.
- Chrousos GP, et al., *J Clin Endocrinol Metab*, 2004;89:563–4.
- Chrousos GP, *Am J Med*, 2004;117:204–7.
- Galon J, et al., *FASEB J*, 2002;16(1):61–71.
- Zhou J, Cidlowski JA, *Steroids*, 2005;70(5-7):407–17.
- Duma D, et al., *J Steroid Biochem Mol Biol*, 2006;102(1–5):11–21.
- Pratt WB, *J Biol Chem*, 1993;268(29):21455–8.
- Terry LJ, et al., *Science*, 2007;318(5855):1412–16.
- Bamberger CM, Schulte HM, Chrousos GP, *Endocr Rev*, 1996;17(3):245–61.
- Schaaf MJ, Cidlowski JA, *J Steroid Biochem Mol Biol*, 2002;83(1–5):37–48.
- Jonat C, et al., *Cell*, 1990;62(6):1189–204.
- Scheinman RI, et al., *Mol Cell Biol*, 1995;15(2):943–53.
- Chrousos GP, Kino T, *Sci STKE*, 2005;304:48.
- Kino T, Chrousos G, *J Allergy Clin Immunol*, 2002;109(4):609–13.
- McKenna NJ, et al., *Endocr Rev*, 1999;20(3):321–44.
- McKenna NJ, et al., *J Steroid Biochem Mol Biol*, 1999;69:3–12.
- McKenna NJ, O'Malley BW, *Cell*, 2002;108:465–74.
- Auboeuf D, Honig A, Berget SM, *Science*, 2002;298:416–19.
- Hittelman AB, et al., *EMBO J*, 1999;18(19):5380–88.
- Heery DM, et al., *Nature*, 1997;387(6634):733–6.
- Kino T, Chrousos GP, *J Endocrinol*, 2001;169(3):437–45.
- Chrousos G, In: *Modern Endocrinology Series*. In: Chrousos GP, Olefsky JM, Samols E (eds), Lippincott, Williams & Wilkins; Philadelphia, PA, 2002;542.
- Kino T, et al., *J Steroid Biochem Mol Biol*, 2003;85(2–5):457–67.
- Chrousos GP, Kino T, *Stress*, 2007;10(2):213–9.
- Vingerhoeds AC, et al., *J Clin Endocrinol Metab*, 1976;43(5):1128–33.
- Chrousos GP, et al., *J Clin Invest*, 1982;69(6):1261–9.
- Chrousos GP, et al., *Ann Intern Med*, 1993;119(11):1113–24.
- Kino T, et al., *Ann N Y Acad Sci*, 2002;970:101–11.
- Charmandari E, et al., *Ann N Y Acad Sci*, 2004;1024:168–81.
- Charmandari E, et al., *J Clin Endocrinol Metab*, 2008;93(5):1563–72.
- Karl M, et al., *Proc Assoc Am Physicians*, 1996;108(4):296–307.
- Hurley DM, et al., *J Clin Invest*, 1991;87(2):680–86.
- Karl M, et al., *J Clin Endocrinol Metab*, 1993;76(3):683–9.
- Malchoff DM, et al., *J Clin Invest*, 1993;91(5):1918–25.
- Kino T, et al., *J Clin Endocrinol Metab*, 2001;86(11):5600–8.
- Ruiz M, et al., *Clin Endocrinol (Oxf)*, 2001;55(3):363–71.
- Mendonca BB, et al., *J Clin Endocrinol Metab*, 2002;87(4):1805–9.
- Vottero A, et al., *J Clin Endocrinol Metab*, 2002;87(6):2658–67.
- Charmandari E, et al., *J Clin Endocrinol Metab*, 2004;89(4):1939–49.
- Charmandari E, et al., *J Clin Endocrinol Metab*, 2005;90(6):3696–705.
- Charmandari E, et al., *J Clin Endocrinol Metab*, 2006;91(4):1535–43.
- Charmandari E, et al., *J Clin Endocrinol Metab*, 2007;92(10):3986–90.
- Tomlinson JW, et al., *Endocr Rev*, 2004;25(5):831–66.
- Wilson JD, et al., *Endocr Rev*, 1993;14(5):577–93.
- Huizenga NA, et al., *J Clin Endocrinol Metab*, 2000;85(5):2076–81.
- Kino T, et al., *Mol Med*, 2004;10(7–12):80–88.
- Savory JG, et al., *Mol Cell Biol*, 1999;19(2):1025–37.
- Picard D, Yamamoto KR, *EMBO J*, 1987;6(11):3333–40.
- Qi M, et al., *Mol Endocrinol*, 1989;3(8):1279–88.
- Wikstrom AC, et al., *Endocrinology*, 1987;120(4):1232–42.
- Holaska JM, et al., *Mol Cell Biol*, 2002;22(17):6286–97.
- Black BE, et al., *Curr Biol*, 2001;11(22):1749–58.
- Dahlman-Wright K, et al., *J Biol Chem*, 1991;266(5):3107–12.
- Umesono K, Evans RM, *Cell*, 1989;57(7):1139–46.
- Liden J, et al., *J Biol Chem*, 1997;272(34):21467–72.
- Reichardt HM, et al., *Cell*, 1998;93(4):531–41.
- Tao Y, et al., *J Biol Chem*, 2001;276(4):2329–32.
- Ding XF, et al., *Mol Endocrinol*, 1998;12(2):302–13.
- Hong H, et al., *GRIP1, Mol Cell Biol*, 1997;17(5):2735–44.
- Hong H, et al., *GRIP1, Proc Natl Acad Sci USA*, 1996;93(10):4948–52.
- Webster JL, et al., *Annu Rev Immunol*, 2002;20:125–63.
- Chrousos GP, *N Engl J Med*, 1995;332:1351–62.
- Franchimont D, et al., *Neuroimmunomodulation*, 2002;10(5):247–60.
- Rhen T, Cidlowski JA, *N Engl J Med*, 2005;353(16):1711–23.
- McKay LI, Cidlowski JA, *Endocr Rev*, 1999;20:435–59.
- Stellato C, *Proc Am Thorac Soc*, 2004;1(3):255–63.
- Gille J, et al., *J Invest Dermatol*, 2001;117:1581–7.
- Franchimont D, et al., *J Clin Endocrinol Metab*, 1999;84(8):2834–9.
- Kam JC, et al., *J Immunol*, 1993;151(7):3460–66.
- Rakasz E, et al., *Scand J Immunol*, 1993;37(6):684–9.
- Salkowski CA, Vogel SN, *J Immunol*, 1992;148(9):2770–77.
- Spahn JD, et al., *J Immunol*, 1996;157(6):2654–9.
- Oakley RH, et al., *J Biol Chem*, 1999;274(39):27857–66.
- Charmandari E, et al., *Mol Endocrinol*, 2005;19(1):52–64.
- Adcock IM, et al., *J Exp Med*, 1995;182(6):1951–8.
- Leung DY, et al., *J Exp Med*, 1997;186(9):1567–74.
- Honda M, et al., *Gastroenterology*, 2000;118(5):859–66.
- Chikanza IC, *Ann N Y Acad Sci*, 2002;966:39–48.
- Meduri GU, et al., *Neuroimmunomodulation*, 2005;12(6):321–38.
- Meduri GU, Yates CR, *Ann N Y Acad Sci*, 2004;1024:24–53.
- Bantel H, et al., *Am J Gastroenterol*, 2000;95(7):1845–6.
- Bantel H, et al., *FASEB J*, 2002;16(13):1832–4.
- Farrell RJ, et al., *Gastroenterology*, 2000;118(2):279–88.
- Maillefert JF, et al., *Br J Rheumatol*, 1996;35(5):430–35.
- Zanker B, et al., *Transplant Proc*, 1995;27(1):925–6.
- Diaz-Borjon A, et al., *Joint Bone Spine*, 2000;67(1):40–48.
- Farrell RJ, et al., *Aliment Pharmacol Ther*, 2002;16(5):1021–31.
- Imhof A, Wolffe AP, *Curr Biol*, 1998;8(12):R422–4.
- Ito K, et al., *Mol Cell Biol*, 2000;20(18):6891–903.
- Ito K, et al., *Biochem Biophys Res Commun*, 2004;315(1):2405.
- Ito K, et al., *J Exp Med*, 2006;203(1):7–13.
- Glozak MA, et al., *Gene*, 2005;363:15–23.
- Fu M, et al., *Pestell RG, Biochem Pharmacol*, 2004;68(6):1199–208.
- Rogatsky I, et al., *Proc Natl Acad Sci USA*, 1998;95(5):2050–55.
- Irusen E, et al., *J Allergy Clin Immunol*, 2002;109(4):649–57.